

- **THEME: NEW MANUFACTURING TECHNOLOGIES**
- **ALIGNMENT TURNING FOR HIGH-PRECISION OPTICAL SYSTEMS**
- **ASML ADOPTS A CIRCULAR ECONOMY MODEL**
- **MINIATURE FLEXURE-BASED GONIOMETER WITH MINIMISED PARASITIC MOTION**

## PUBLICATION INFORMATION

### Objective

Professional journal on precision engineering and the official organ of DSPE, the Dutch Society for Precision Engineering. Mikroniek provides current information about scientific, technical and business developments in the fields of precision engineering, mechatronics and optics. The journal is read by researchers and professionals in charge of the development and realisation of advanced precision machinery.



### Publisher

DSPE  
Julie van Stiphout  
High Tech Campus 1, 5656 AE Eindhoven  
PO Box 80036, 5600 JW Eindhoven  
info@dspe.nl, www.dspe.nl

### Editorial board

Prof.dr.ir. Just Herder (chairman, Delft University of Technology),  
Servaas Bank (VDL ETG), B.Sc.,  
Maarten Dekker, M.Sc. (Philips),  
Otte Haitisma, M.Sc. (Demcon),  
dr.ir. Jan de Jong (University of Twente),  
Erik Manders, M.Sc. (Philips Engineering Solutions),  
dr.ir. Pieter Nuij (MaDyCon),  
dr.ir. Ioannis Proimadis (VDL ETG),  
Maurice Teuwen, M.Sc. (Janssen Precision Engineering)

### Editor

Hans van Eerden, hans.vaneerden@dspe.nl

### Advertising canvasser

Gerrit Kulsdom, Sales & Services  
+31 (0)229 – 211 211, gerrit@salesandservices.nl

### Design and realisation

Drukkerij Snep, Eindhoven  
+31 (0)40 – 251 99 29, info@snep.nl

### Subscription

Mikroniek is for DSPE members only.  
DSPE membership is open to institutes, companies, self-employed professionals and private persons, and starts at € 80.00 (excl. VAT) per year.

Mikroniek appears six times a year.

© Nothing from this publication may be reproduced or copied without the express permission of the publisher.

ISSN 0026-3699



The cover image (antenna made by template-based 3D microfabrication) is courtesy of Horizon Microtechnologies. Read the article on page 18 ff.

# IN THIS ISSUE

## THEME: NEW MANUFACTURING TECHNOLOGIES

### 05

#### True to the optical axis

TRIOPTICS forerunner in alignment turning for high-precision optical systems.

### 10

#### New optical architectures

Challenges and opportunities in gradient-index optics.

### 18

#### Coating of complex microparts for added functionality

Applications of 3D template-based microfabrication by Horizon Technologies.

### 22

#### Preserving precision in PEEK printing

Bond3D develops advanced shrink compensation.

### 26

#### Spatial Atomic Layer Deposition

SALD moves toward high-volume production for green growth markets.

### 30

#### Cutting, laser processing and assembly of brittle materials

LouwersHanique makes the most of combined technologies.

### 36

#### Inherent Strain Method

Addressing thermal deformations in Laser Powder Bed Fusion.

### 40

#### Sustainability – The House of Re-use

### 44

#### Design principles – Three parasitic motion reduction strategies

### 49

#### Event report – euspen's International Conference & Exhibition 2023

### 52

#### Event preview – DSPE Conference on Precision Mechatronics 2023

### 54

#### Event preview – parts2clean

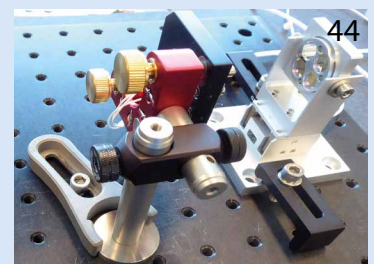
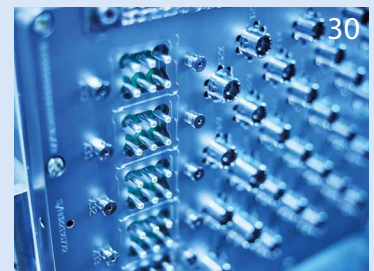

## FEATURES

### 04 EDITORIAL

Teun van de Sande, CTO of Wefabricate, on modern manufacturing, i.e. producing smarter, with awareness of sustainability, adaptability and durability.

### 17 UPCOMING EVENTS

Including: Precision Fair 2023.

### 57 DSPE

Including: Henny Spaan receives Martin van den Brink Award.

### 60 ECP2 COURSE CALENDAR

Overview of European Certified Precision Engineering courses.

### 61 NEWS

Including: ASPE Jan van Eijk Student Scholarship.

## ON THE EVE OF MODERN MANUFACTURING

Innovation in manufacturing is becoming increasingly important for economic competitiveness and environmental sustainability. Today, our vision should focus on more than just producing more efficiently. It is about producing smarter, with awareness of sustainability, adaptability and durability. Integrating the manufacturing processes is not just about increasing throughput; it is about creating fast, adaptive processes that evolve with customers' needs and global shifts. We are now on the eve of enabling this modern manufacturing.

Automated manufacturing is required to ensure consistent quality and it enables local production. Obviously, the very essence of manufacturing is just creating or producing goods. But modern factories are different. They are no longer greasy and dusty places that churn out products. For some reason that is what people think of when talking about factories. Today's factories are more like ecosystems, complexly linked networks in which information flows as seamlessly as the products they produce. Having a wide variety of in-house capabilities ensures a fully merged and optimised approach to the manufacturing of integrated products, leading to machines performing at their best and addressing manufacturing challenges where it is most effective.

For technological innovations, product design and production will elegantly flow together. A beautifully designed product that is impossible to manufacture efficiently remains just that: a design. The importance of design principles and design for manufacturing cannot be stressed enough. It is what bridges the gap between innovation and practicality. Adding to this the concept of modularity and standardisation, we are looking at products that are not just efficient to produce but also scalable and adaptable to varying customer requirements. Valuable standardisation on both component and manufacturing process level will lead to more re-use. In an age where customisation is in high demand, modular designs facilitated by standardised components and processes promise both uniqueness and scalability.

Wefabricate is reshaping industry norms by constructing the world's most efficient factory, leveraging automation to reduce the environmental impact and optimise resource utilisation. We radically optimise manufacturing flows with advanced automation. With this strategy, we aim to stretch the potential of technology even further, enabling us to produce the highest quality products. We aspire not to be just another factory; we want to be an incubator of sustainable solutions. By launching our own start-ups such as Weheat and Fyllar on the one hand, we can demonstrate the possibilities when our design and manufacturing blueprint is followed. On the other hand, we want to promote green heating solutions and reduce plastic waste, proactively driving a more sustainable future.

In the great story of innovation, factories are not just manufacturing products, but creating the future. Automated manufacturing is nice and crucial, but humans are absolutely indispensable to set up and arrange the entire workflow, both digitally and physically. Behind every machine, every process and every innovation, stand the valuable minds of talented engineers. Let's stimulate a community of the brightest minds; the dreamers, rebels and catalysts for change, who don't just see the world for what it is, but for what it could be. It is their imagination, skill and dedication that will shape the products, the new factories and the future of modern manufacturing.

Teun van de Sande  
CTO Wefabricate  
[teun.van.de.sande@wefabricate.com](mailto:teun.van.de.sande@wefabricate.com), [www.wefabricate.com](http://www.wefabricate.com)



# TRUE TO THE OPTICAL AXIS

**The demand for high-precision optical manufacturing technologies is increasing. This includes the need to align passive optical elements such as single lenses and lens systems as well as active optical elements such as laser diodes. For passive and active optical components, alignment turning meets the increasing industrial requirements for precision, freedom of design, automation, and competitive production times. Often, the use of alignment turning is a robust and more efficient alternative to the active alignment of optical systems.**

CHRISTIAN BUSS

## Introduction

The key principles of alignment turning have been known for about 50 years now. Instead of trying to manually align optical elements (mostly lenses) to increasingly high accuracy requirements using traditional shimming methods, an ultra-precision machine takes the mounted lenses and cuts precision reference surfaces onto the mount. The lenses are then assembled with little to no further adjustment. In effect, ultra-precision diamond cutting replaces manual, error-prone labour, resulting in both shorter assembly time and higher accuracy for high-precision objective lenses.

In earlier days, only large corporations with substantial budgets have developed their own solutions based on these concepts. However, in the past 10 to 15 years, with the ongoing improvement of measurement technology and industrial control systems, the underlying technology has evolved significantly. This has led to the emergence of specialised alignment turning machines suitable for all

fields of optics assembly. Whether for small microscope optics or large semiconductor lenses, there are solutions available to meet the specific needs and challenges of nearly all industries.

TRIOPTICS has played a significant role in this field in the past years, with an installed base of more than seventy alignment turning machines in different market segments. With these machines, it actively enables customers worldwide to produce high-precision objective lenses more efficiently and cost-effectively than ever before.

## Alignment turning for mounted lenses

There are many challenges in the creation of high-precision objective lenses. These start with developing a good optics design and a suitable opto-mechanical concept. Assuming that the individual (glass) parts are made well, the main challenge is to minimise centration errors and control the air spacings between the lenses.

It has been known for over a hundred years that the best way of achieving this is to glue (or pot) the lenses into individual mounts that can then be put into a barrel with spacer shims between the mounts to account for any deviating centre thicknesses of the lenses. This approach, which is similar to a “poker chip assembly”, results in high levels of accuracy. The selection of the appropriate mounting technique is based on the tolerance analysis, the size and weight requirements for the assembly, the environmental conditions of the final use of the objective lens, the production quantities, and the cost targets.

Today, the target accuracies for an assembled, high-precision objective lens are often lower than 1 to 2  $\mu\text{m}$  of decentration of the optical axis along the objective lens and 1 to 2  $\mu\text{m}$  of error of the air gaps between the lenses. In order to achieve these levels of accuracy in the final objective lens, the target accuracies of an individual mounted lens must be even smaller. Here, a maximum

## About TRIOPTICS

TRIOPTICS supplied the first systems for alignment turning over 20 years ago and has been building its own complete alignment turning machines for the past 15 years. The expertise ranges from specialised knowledge about tools, materials, fixtures, and process parameters to the overall process of optics assembly for a wide range of industries. With the centration measurement device and the cementing, bonding, and gluing stations, the company’s extensive experience can be leveraged to solve specific challenges for its customers – whether it is for a small company entering the market or for a large corporation seeking to increase the efficiency of their production.

[WWW.TRIOPTICS.COM](http://WWW.TRIOPTICS.COM)

### AUTHOR’S NOTE

Dr.-Ing. Christian Buß is head of R&D Alignment Turning Systems at TRIOPTICS in Wedel (Germany). Part of the content described in this article was presented at the DSPE Optomechatronics Symposium 2023.

of 1  $\mu\text{m}$  of decentration and an accuracy of 1  $\mu\text{m}$  of the flange-to-vertex distance of the lens is required. Any shim-based assembly method will require disproportionately greater effort on the part of the operator to achieve good accuracy. The unique advantage of alignment turning is its ability to produce accurate centration and flange-to-vertex distances in just one automated step.

*The principle of alignment turning*

Traditionally, a lens is aligned to its mount and then glued in place with the highest possible precision (cf. OptiCentric® Bonding). Then, the mount is fitted into a barrel. Since the mount is made before the lens is glued to it, the mount cannot accommodate any (thickness) deviation of the actual lens from the nominal design. That is why shims must be used during the assembly process. Also, to achieve a reasonable production rate, fast UV-curing adhesives have to be used for this technique, resulting in relatively high stress on the lens.

Alignment turning works “the other way round” (see the box on the right). A lens is glued to a mount, which

is slightly larger than necessary. Then this mount is loaded onto the alignment turning machine and cut to size, considering the concentricity of the optical axis, the cell axis, and the lens thickness. Since the gluing and alignment are two separate process steps, the choice of adhesive is no longer a determining factor for the process time. Slow-curing RTV-glues and even designs with threaded retainer rings (as often seen in high-power laser applications) are suitable for alignment turning.

### Centration measurement, alignment, cementing and bonding

The precise centration and alignment of a lens is crucial for the image quality of the optical system. According to ISO 10110, a centration error is given when the optical axis of a lens does not coincide with a reference axis due to a difference in position and direction. Centration errors occur during the cementing, aligning, and fixing of lenses. Therefore, the precise requirements of optical systems can be best met if all manufacturing steps are uniformly designed and incorporated into a single measurement and manufacturing system. The centration error of a single lens is defined as shown in Figure 1.

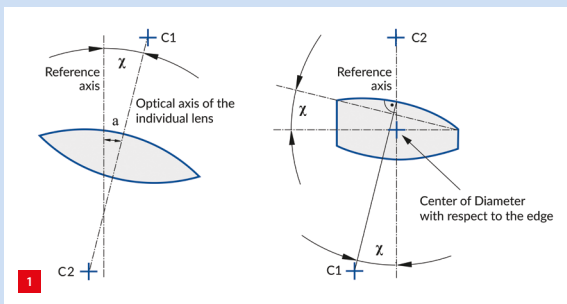

The optical axis of a single lens is the line connecting the centres of curvature of the two spherical surfaces (C1 and C2). The centration error is then defined by the angle  $\chi$  and the distance 'a' to a given reference axis.

### What is alignment turning?

In the alignment turning process, reference surfaces on a mount (diameter and flange) are machined true to the optical axis of a lens. Two methods exist for the alignment turning of mounted lenses: chuck-based alignment turning and CNC-based alignment turning. Both processes have specific advantages and disadvantages, such as greater or less flexibility and process time. After machining, the alignment-turned mounts typically have no relevant differences, irrespective of the process used.

Schematic representations of the chuck-based and the CNC-based alignment turning process are shown in Figures 2 and 3, respectively.

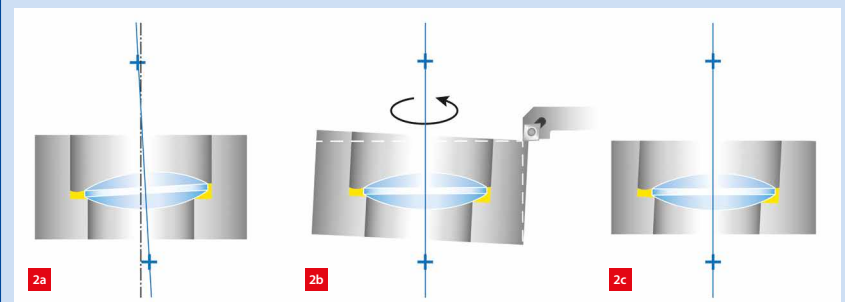

Chuck-based alignment turning process.  
 (a) The centration of the optical axis of the lens with respect to the spindle axis is determined.  
 (b) The chuck is aligned so that the optical axis of the lens corresponds to the spindle axis of the alignment turning machine. Then the reference surfaces of the mount are turned.  
 (c) The reference surfaces are then aligned to the optical axis.

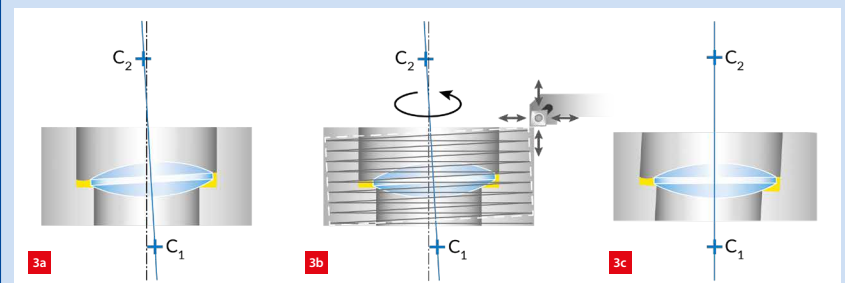

CNC-based alignment turning process.  
 (a) The centration of the optical axis of the lens with respect to the spindle axis is determined.  
 (b) The linear axes of the machine move in coordinated motion with the rotating spindle offset by the centration error. At the same time, the machine axes cut the tilted diameter and flange surfaces according to the centration measurement.  
 (c) The reference surfaces are then aligned to the optical axis.

[WWW.TRIOPTICS.COM/KNOWLEDGE-BASE/ALIGNMENT-TURNING-OF-OPTICAL-ASSEMBLIES](http://WWW.TRIOPTICS.COM/KNOWLEDGE-BASE/ALIGNMENT-TURNING-OF-OPTICAL-ASSEMBLIES)

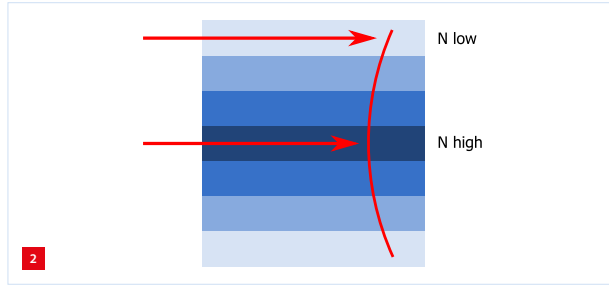

Curvature (and therefore optical focusing power) imparted to a wavefront by propagation through a radially varying refractive index.

### GRIN lens manufacture and use to date

Exner and Matthiessen also observed they could artificially generate the focusing effect seen in insect eyes by soaking gelatine cylinders in water. This process was further refined by Robert W. Wood, who developed focusing GRIN cylinders with planar faces, which we now refer to eponymously as a Wood lens [2].

Across a similar timeframe, the potential of GRIN media for aberration correction of imaging systems was observed by several authors. Famously, the perfect imaging systems of Maxwell and Luneburg (Figure 3) showed how GRIN media could be used in optical systems, although no optical technology could create them at the time.

The foundations of aberration theory for GRIN media were laid by Buchdahl [3]. This set the scene for a flurry of research activity in the latter half of the 20th century, as computational ray-tracing allowed analysis of more general GRIN problems when it was realised that GRIN lenses could provide improved aberration correction over systems of spherical lenses, potentially reducing size, mass and cost or improving image quality. In more modern times, these improvements fall under a widely adopted industry acronym, SWaP-C (size, weight and power, for minimised cost).

A myriad of GRIN manufacture techniques and designs were generated during this time [5]. Techniques such as ion-exchange/stuffing, neutron irradiation and CVD growth all showed promise as means to prepare GRIN lenses.

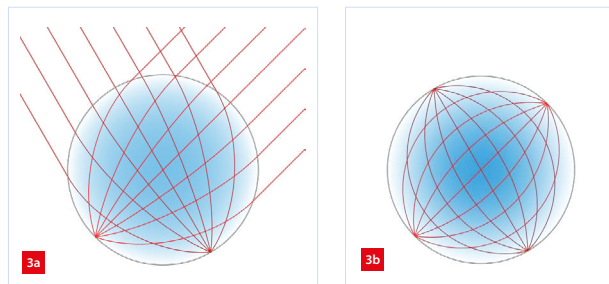

Perfect imaging designs [4].  
(a) Luneburg.  
(b) Maxwell.

Concurrently however, the development of cheaper aspheres (that offered comparable theoretical SWaP-C improvements to GRIN) through processes such as CNC polishing, diamond turning, and injection moulding meant that GRIN lenses were commercially restricted to niche commercial applications, such as precision borescopes, coupling lenses, copier arrays, and most ubiquitously, optical fibre. Processes developed during this period were less well suited to large-diameter lenses required in more general imaging applications.

### New GRIN technologies

In the 21st century, new industrial technologies in adjacent fields have enabled new means to generate GRIN lenses (Figure 4). Multilayer co-extrusion of polymers enabled a new layer-based GRIN technology allowing manufacture of spherical and axial GRINs with arbitrary index distribution in one dimension (Figure 4c) [6]. Additive manufacture has enabled new processes for the assembly of GRIN media from multiple base materials and with arbitrary distribution [7][8], while the industrialisation of ultra-fast laser pulses has allowed the development of means to directly “write” index variation into homogeneous optical materials [9][10].

It is the generation of an arbitrary GRIN distribution with increased index variation (often referred to as  $\Delta N$ ) that is a particularly exciting prospect for GRIN optics, allowing new applications where GRIN offers benefits beyond those of aspheres or diffractive surfaces. In the past, GRINs tended to belong to one of a few basic distribution types, such as axial, radial, or spherical (as shown in Figures 4a and 4b), with fine control of the index distribution dictated by natural processes such as diffusion. This ultimately limited the distribution and  $\Delta N$  of the GRIN, and with it, the aberration correction potential.

With these new emerging technologies, previous limitations are progressively being overcome, with manufacture of an arbitrary GRIN distribution (Figures 4d and 4e) now a reality.  $\Delta N$  in excess of 0.2 is now offered by several GRIN processes. Excitingly, additive manufacture processes also enable tailored control over the chromatic dispersive properties of the GRIN. Chromatic aberration is generated by all conventional singlet homogeneous lenses when presented with a finite waveband. Blue light is refracted more than red light resulting in the focus shifting for each wavelength in the system (Figure 5a). A well-known metric by which the dispersive properties of optical materials are measured is the Abbé  $V$  value, defined for three sequential wavelengths spanning the waveband of the design problem of interest ( $\lambda_{\text{short}} < \lambda_{\text{mid}} < \lambda_{\text{long}}$ ):

$$V = (N_{\text{mid}} - 1) / (N_{\text{short}} - N_{\text{long}})$$

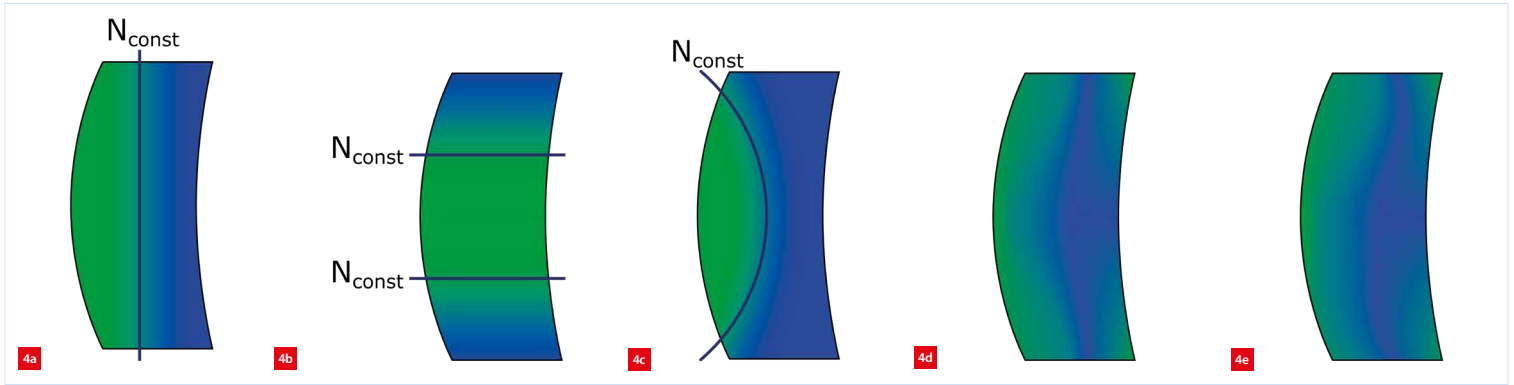

GRIN distribution types with increasing manufacture complexity from left to right.

- (a) Axial.
- (b) Radial.
- (c) Spherical.
- (d) General rotationally symmetric.
- (e) Freeform.

For visible waveband materials, the quantities  $N_d$  and  $V_d$  are very widely used.  $N_d$  indicates refractive index at the Fraunhofer 'd' line of 587.6 nm. The quantity  $V_d$  is defined for the Fraunhofer C, d, and F spectral lines (656.3 nm, 587.6 nm, and 486.1 nm, respectively). GRIN materials have their own  $V$  value, defined by the index delta between constituent materials at the same wavelengths:

$$V_{GRIN} = \Delta N_{mid} (\Delta N_{short} - \Delta N_{long})$$

$V_{GRIN}$  can take on a very wide range of values compared to the  $V$  value of homogeneous materials (which typically ranges between 20 and 90 for visible-waveband materials).  $V_{GRIN}$  can be very small (highly dispersive, more so than homogeneous materials), near infinite (non-dispersive, see Figure 5b) or even negative (which produces chromatic aberration of negative sign, see Figure 5c). Various quantities of example combinations of GRIN constituent materials produced by NanoVox are shown in Table 1 and Table 2. These materials

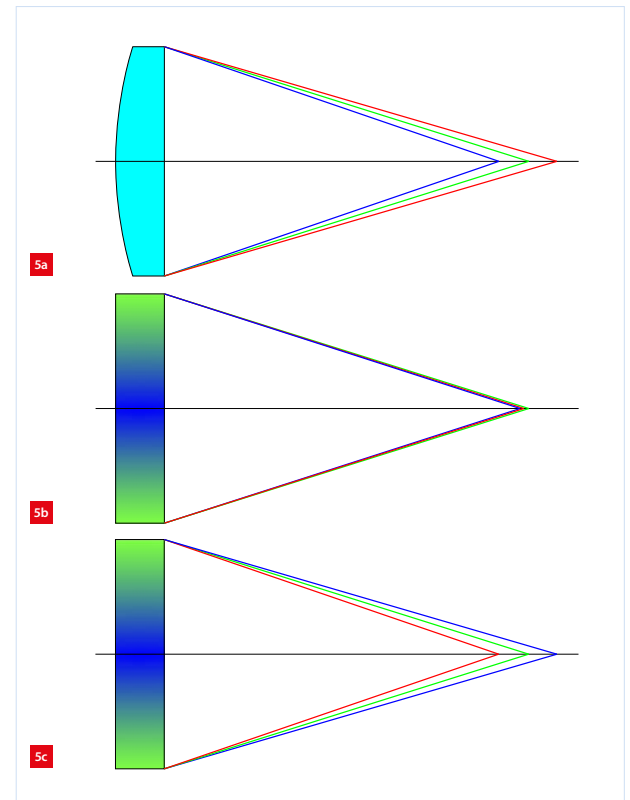

Chromatic aberration as generated by different lens types.

- (a) Conventional homogeneous lens displaying chromatic aberration.
- (b) GRIN lens with near-zero chromatic aberration.
- (c) GRIN lens with negative chromatic aberration.

**Table 1**

NanoVox nanoparticle-doped polymer properties.

Material	$N_d$	$V_d$	Density (g/cm <sup>3</sup> )
VYIX1060	1.45621	24.0	1.42
VZBX2000	1.62308	46.7	1.15
VZAX1500	1.70432	18.6	1.44

**Table 2**

NanoVox GRIN-combination optical properties.

Combination	$\Delta N_d$	$V_{GRIN}$
VYIX1060-VZBX2000	0.167	-29.52
VYIX1060-VZAX1500	0.248	13.16
VZBX2000-VZAX1500	0.081	3.32

are generated by doping of UV-curable monomers with refractive-index-modifying nanoparticles.

### Applications of modern GRIN technologies

With the wide variation available in chromatic properties of GRIN media, a natural key application of this technology is chromatic aberration correction. Figure 6 illustrates three common means via which this is achieved. The first, well-known means is via an achromatic doublet. Two lenses of dissimilar  $V$  values and opposing signs of focal length are cemented together such that net positive focusing power is generated, but chromatic aberration is cancelled out according to the achromatic condition: