

# SMART DISC – application in an ASML wafer stepper

THEO J.A. DE VRIES, JAN HOLTERMAN, MARINUS P. KOSTER  
EL-RT, Drebbel Institute, University of Twente, Enschede, Netherlands

BASTIAAN S.H. JANSEN  
ASM Lithography, Veldhoven, Netherlands

*Tuesday, 6th Februari, 18.30 h*

## Abstract

High-precision machines typically suffer from small, but annoying, badly damped vibrations. In case such a vibration problem can not be solved passively, a solution may be found in active vibration control. In this respect, research at the Drebbel Institute is aimed at the development of a device called SMART DISC (SD). It is envisioned as an active structural element, consisting of a piezoelectric position actuator co-located with a piezoelectric force sensor, and control and amplifier electronics. As an industrial, three-dimensional test set-up for evaluation of the performance of SD's, the lens support of an ASML wafer stepper has been chosen. By inserting SD's in the lens support, and applying Integral Force Feedback control, the relative tilt of the lens relative to the main plate has been reduced by more than a factor 3. The absolute acceleration level of the top of the lens at its dominant resonance frequency has been successfully reduced to less than 10% of the original level.

Proc. Philips Conference on Applications of Control Technology PACT'01 (Februari 2001, Eindhoven, Netherlands), G. van Baars (ed.), Philips Centre for Industrial Technology, doc. Code CTR595-01-0005



## INTRODUCTION

High-precision machines typically suffer from small, but annoying, vibrations. These may either be induced by environmental vibrations transmitted by the floor or the surrounding air, or result as an unwanted side effect due to actuators inside the machine. A straightforward solution to many vibration problems is to increase the stiffness within a machine. There is however a practical limit in passively increasing the stiffness of a structure. Furthermore, due to dedicated structural design rules, vibrations in high-precision machines are typically badly damped. Introducing additional passive damping into high-precision structures is complicated, as the stresses and strains to be damped are very small [1,2].

Because of the indicated restrictions of passive solutions, much research effort is put into active vibration control strategies worldwide. Because of the relative ease of implementation and guaranteed stability, active structural elements for vibration control with co-located sensing and actuation have gained much interest, see e.g. [3, 4]. At the Cornelis J. Drebbel Institute for Systems Engineering at the University of Twente research is aimed at the development of a Smart Disc (SD), which is envisioned as a *load-bearing* active structural element with integrated force sensing, piezo-electric position actuation, and control [2,5, 6]. By inserting Smart Discs at appropriate locations in a high-precision machine frame, the effective damping as well as the effective stiffness of the frame may be improved.

At the PACT'96 we have reported a first experiment for evaluating the 'SD concept' that was performed on a one-dimensional laboratory test set-up in which a single prototype SD was incorporated [5]. In that research the feasibility of effective stiffness enhancement for low frequencies (up to 10 Hz) has been proven. In this paper, our aim is to demonstrate the vibration reduction performance of SD's at higher frequencies, e.g. around 100 Hz, and in a full 3-D set-up. The industrial test set-up that is used for this purpose is a lens support of an ASML wafer stepper.

In the next section, we first describe the experiment. Then, the measurement results are presented. The paper concludes with a discussion of the results. Space limitations prevent us from giving a full exposure; for details the reader is referred to [7].

## EXPERIMENT DESCRIPTION

### Set-up

The ASML PAS5500 wafer stepper is a good example of a carefully constructed machine of which the performance is limited by a vibration problem. Figure 1 shows the machine parts that are relevant for the present study; in the set-up, the (expensive) lens has been replaced with a dummy steel body with approximately the same mechanical characteristics. In order to maximise the imaging performance of the wafer stepper, it is important that the (dummy) lens does not move relative to the main plate. However, the lens exhibits badly damped eigen modes at relatively low frequencies due to compliance in the mechanical interface between lens and main plate. The lowest eigen mode, called 'joystick

mode' because the mode shape has the form of the motion of a joystick, contributes most to the relative displacement. Excitation of the 'joystick mode' has been shown to be the result of acoustics, mainly caused by the machine itself and clean room acoustics [8]. Removal of the excitation sources or (further) vibration reduction by passive means is not feasible. Hence, our research focuses on reducing the amplitude of this 'joystick mode' by means of SD's.

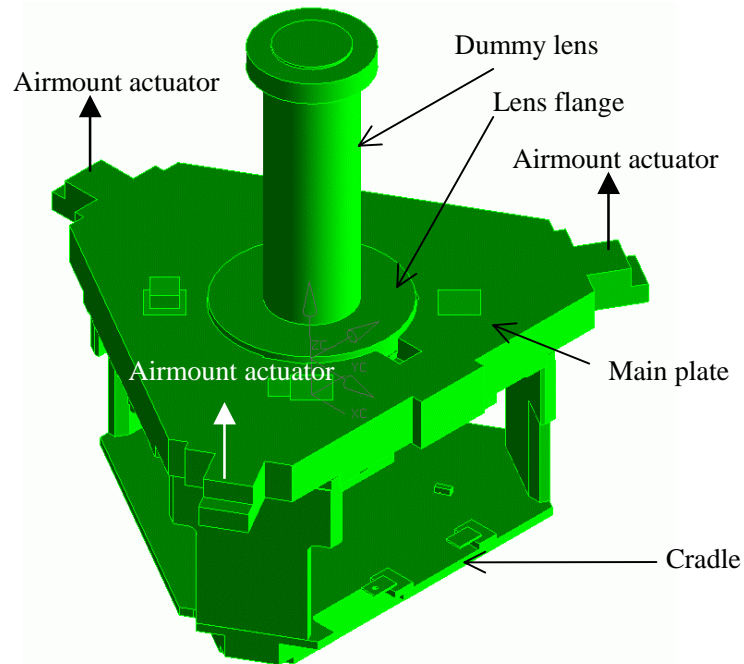

*Fig. 1 Relevant parts of the test set-up*

The main plate is isolated from floor vibrations by means of three airmounts, which combine both active and passive means to achieve this isolation. These airmounts can also be used to apply a commanded force to the main plate.

### Smart Lens Supports

The lens mechanically interfaces to the main plate by means of three lens support blocks, which are located between lens flange and main plate at radially symmetric positions. For the experiment, the original lens supports have been replaced by newly designed lens supports that each incorporate one Smart Disc [9]. These modified designs will be called Smart Lens Supports or SLS's for short. Figure 2 shows the design, in which '05' indicates one of the two piezo stacks; each stack consists of a piezo actuator and sensor on top of each other. The main consideration behind this design has been to create a lens support that is, in terms of its outer dimensions, a one-to-one replacement of the original, and only adds the sensors and actuators in a suitable way. This makes a direct comparison between the set-up with and without SLS's possible.

The SLS is not a 'true' SD, in the sense that amplifiers and signal processing electronics have not been integrated into the device. Dedicated

amplifiers were built for this experiment and incorporated in a separate housing.

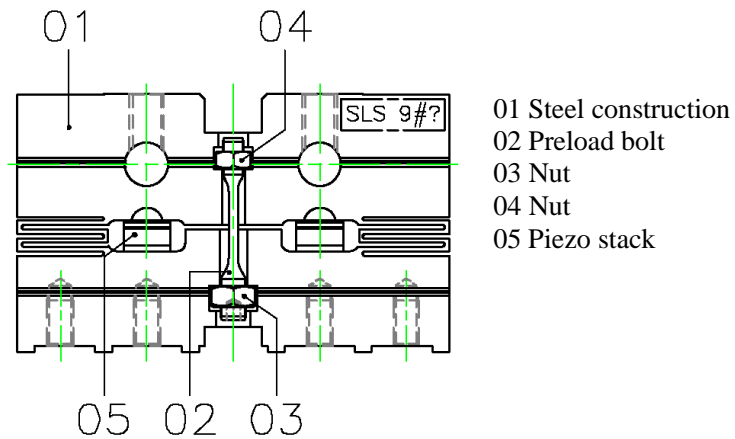

Fig.2 The Smart Lens Support design

Figure 3 depicts a dynamic model of the lens set-up with SLS, in which the lowest mode of vibration is included only. Bode plots of the transfer functions are depicted in figure 4. The figure does not show the actual characteristics of the real system; we have normalized the resonance frequency to  $\omega_e = 2\pi 100$  (rad/s),  $\rho = \omega_a / \omega_e = 0.5$  and the relative damping has been set to 0.5%, a typical value for structural damping in high-precision machine frames.

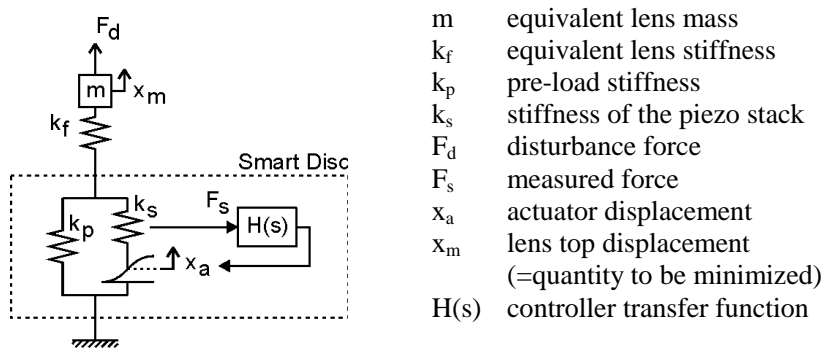

Fig. 3 Simple dynamic model of the SD-supported lens

From figure 4 it is obvious that the main problem within the mechanical structure is the badly damped resonance. By choosing a suitable control law  $H(s)$  that closes the loop between  $F_s$  and  $x_a$  within the Smart Disc, the resonance may be damped. To that end, Integral Force Feedback [10] (IFF) is a suitable choice, which implies the following transfer:

$$H(s) = \frac{K}{s + \alpha}$$

The root-locus of figure 5 shows the effect of closing the loop with IFF for  $\alpha$  close to 0. Due to the fact that the actuator and sensor are collocated, the zeros and poles (even those corresponding to unmodeled

structural dynamics) alternate along the imaginary axis. As a consequence all poles are drawn into the left half of the  $s$ -plane, i.e., IFF damps (and thus stabilizes) all resonances. This robust stability feature is the main virtue of IFF.

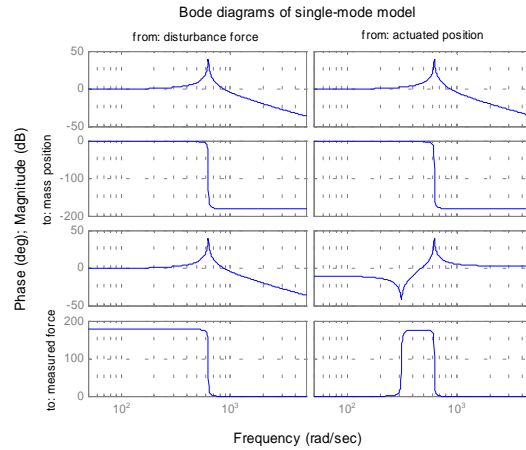

Fig. 4 Bode plots of relevant plant transfers for the single mode model

Figure 5 also shows that for larger gains, the (damped) eigenfrequency of the lowest vibration mode will decrease significantly, i.e., the effective low frequency stiffness decreases. Hence, when applying IFF there is a trade-off between ‘active damping augmentation’ and ‘effective stiffness loss’. Therefore, an algorithm was devised that optimizes the IFF controller settings for given mechanical system parameters, under the assumptions that the spectrum of  $F_d$  is flat and that the control goal is to minimize the residual power present in  $x_m$  [11]. This algorithm has been used to select the controller parameters; the resulting control law was implemented using a dSpace system that runs at a 10 kHz sampling frequency.

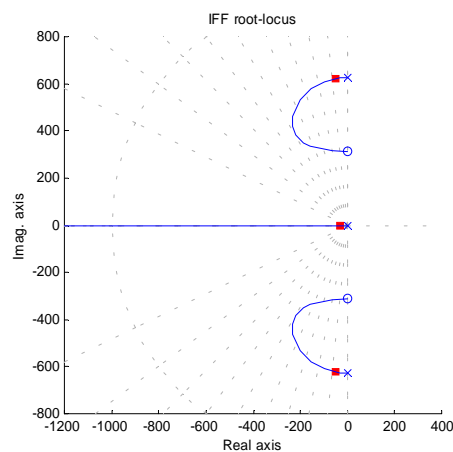

Fig. 5 Root locus for the simple dynamic model with IFF-controller

### Measurement and excitation

The performance of the system is determined by the relative displacement of the lens-top with respect to the main plate. This displacement needs to be obtained under fixed conditions and independent of the SLS, with ‘standard’ equipment.

The airmount actuators can be used for excitation of the relative displacement, as these can exert a pre-defined torque to the main plate around a freely selectable horizontal axis. During the measurements, a band-limited white noise signal (up to 350 Hz) of sufficient amplitude was supplied to the airmount actuators.

Direct measurement of the relative displacement is hard to realize. Instead, this displacement is calculated from measurements of the accelerations of the main plate and the lens. For this, accelerations are measured in two rotational directions for both bodies, therewith assuming that relative displacement is mainly due to rotation.

### RESULTS

Only two main measurement results are presented, namely the relative tilt around one axis, for the conventional supports and for the SLS’s, respectively.

For each measurement, we present the (calculated) relative tilt (upper plot), the corresponding Power Spectral Density (middle) and the cumulative Power Spectral Density (lower). An important measure of performance is given by the  $3\sigma$  value of the relative tilt, which follows from the cumulative PSD. In case of a normally distributed excitation, 99.7% of the values over time are within the  $[-3\sigma, 3\sigma]$ -range.

The measurement results for the system with conventional supports are given in figure 6.

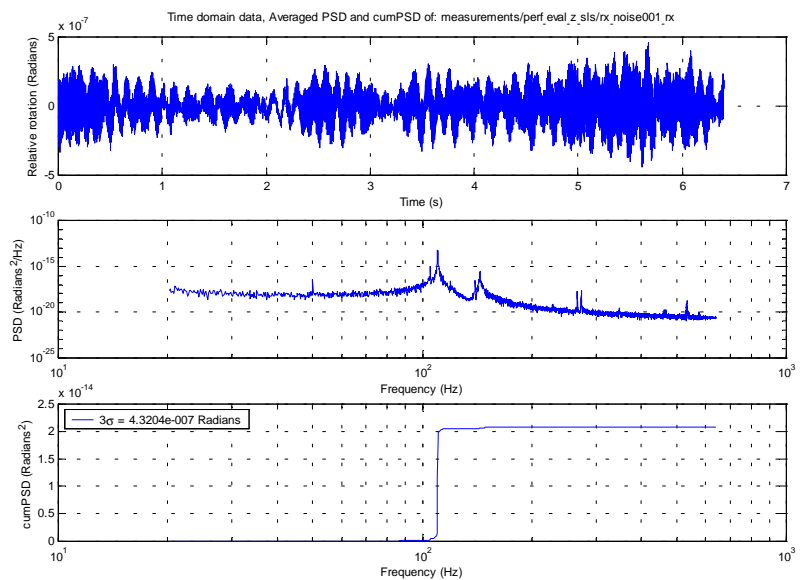

Fig. 6 Relative rotation of the lens – conventional support

Figure 7 shows the same results for the case with SLS's, but without the feedback being active. Figure 8 finally presents the results when the SLS's are active (note the difference in scales).

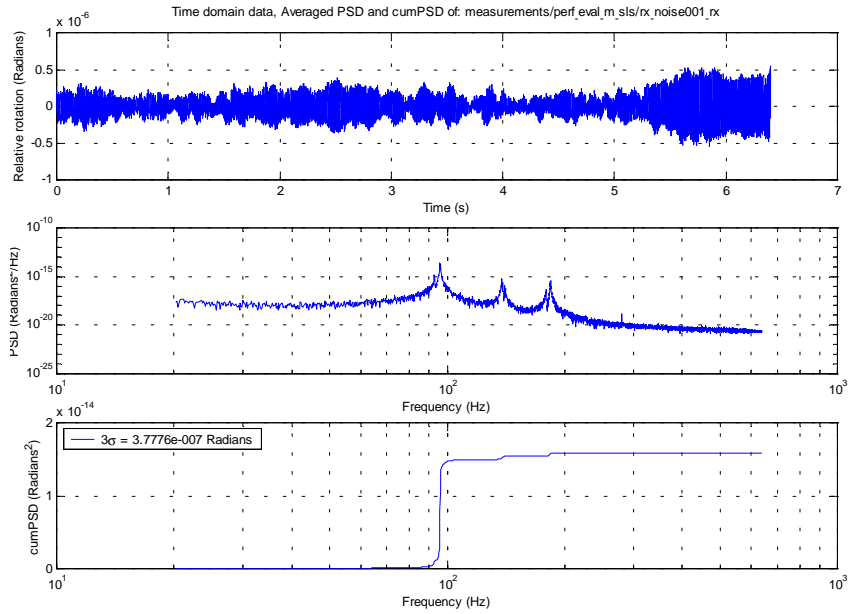

Fig.7 Relative rotation of the lens – *passive* Smart Lens Support

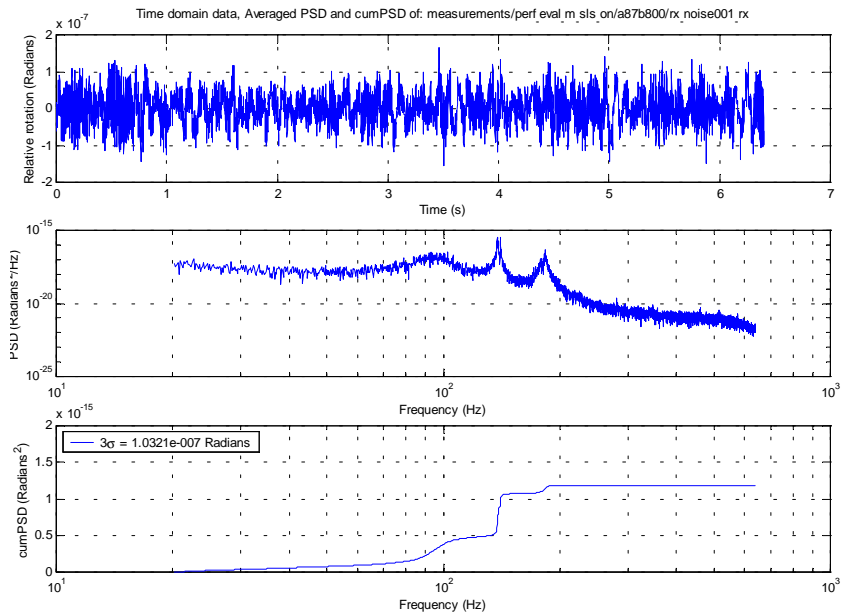

Fig. 8 Relative rotation of the lens – *active* Smart Lens Support



## DISCUSSION

The lower plot in figure 6 shows that the relative rotation of the lens is almost entirely caused by the badly damped lowest eigenmode at about 110 Hz (referred to as 'joystick mode'). The insertion of lens supports equipped with passive Smart Discs (figure 7) resulted in lower resonance frequencies of the lens (at about 95 Hz). This indicates that the stiffness of the so-called 'Smart Lens Support' is lower than the stiffness of the conventional lens supports. The relative rotation of the lens however decreased. This indicates that the 'new' 95 Hz joystick modes are better damped, even with *passive* Smart Discs, than the original 110 Hz joystick modes. Figure 8 reveals that with *active* Smart Discs the relative tilt of the lens can be reduced by more than a factor 3 in a frequency range of 20-350 Hz. The damping of the 95 Hz joystick modes has even increased by more than a factor 6. The absolute acceleration level at the lens-top (not shown in the figures) has decreased by more than a factor 4 in the frequency range of 1-350 Hz. For the joystick modes only, a reduction in absolute acceleration level of more than a factor 10 was observed.

## REFERENCES

- [1] Koster, M.P., (1998), *Constuctieprincipes* (in Dutch), Twente University Press, Enschede, The Netherlands.
- [2] Van Schothorst, G., (1999), "Active Vibration Control using Piezoelectric Smart Discs", in *Proc. SPIE Smart Structures and Materials*, Vol. 3667, pp. 637-648.
- [3] Spangler, R.L., F.M. Russo, and D.A. Palombo, (1997), "A Compact Integrated Piezoelectric Vibration Control Package", in *Proc. SPIE Smart Structures and Materials*, Vol. 3041, pp. 728-740.
- [4] Anderson, E.H., D.M. Moore, J.L. Fanson, and M.A. Ealey, (1990), "Development of an active truss element for control of active structures", in *Optical Engineering*, Vol. 29. No. 11, pp. 1333-1341.
- [5] Koster, M.P., and T.J.A. de Vries, (1996), "Smart Disc", *Proc. Philips Conference on Applications of Control Technology PACT '96*, Epe, The Netherlands.
- [6] <http://www.rt.el.utwente.nl/smartdisc/>
- [7] Jansen, B.S.H., (2000), *Smart Disc tuning and application in an ASML wafer stepper*, M.Sc. thesis (confidential), Report No. 016R2000, Control Laboratory, University of Twente, Enschede, NL.
- [8] Gompel, D. van, (2000), *TAR Effect of ACC + MF cooling on MF / lens vibrations*, mldyta11.doc, internal report (confidential), ASM Lithography, Veldhoven, The Netherlands.
- [9] Tacoma, B.G., (2000), *Mechanical design of Smart Disc integrated in an ASML wafer stepper lens support*, M.Sc. report, Control Laboratory. University of Twente, Enschede, The Netherlands. (To be published)
- [10] Preumont, A. (1997), *Vibration Control of Active Structures, An Introduction*, Kluwer Academic Publishers, Dordrecht, The Netherlands.
- [11] Holterman, J., and T.J.A. de Vries, (2000), "Self tuning integral force feedback", in *Proc. Motion and Vibration Control (MOVIC)*, Singapore.